

Rockfon Infinity™

M

## Contents

---

<b>03</b>	<b>Rockfon Infinity™ Perimeter Trim</b>
04 .....	Quick Ship Program
05 .....	Infinity Standard (Straight Edge)
05 .....	Infinity Engineered (Straight Edge)
06 .....	Infinity R (Reveal Edge)
06 .....	Infinity Z (Razor Edge)
06 .....	Infinity D (for Drywall)
06 .....	Accessories
<b>07</b>	<b>Reflected Ceiling Plans</b>
<b>08</b>	<b>System Integration</b>
<b>09</b>	<b>Specification Data</b>
<b>10</b>	<b>Infinity Specification</b>
<b>11</b>	<b>General Conditions of Sale</b>

## Service

---

### Color Samples

1. Custom color matching requires customer color sample or paint manufacturer and color number.
2. ROCKFON will provide color sample for approval upon request.
3. Service Level begins after receipt of color approval.

### Order Review

Customer Service direct: 1.800.323.7164 / option 1.

### Order Placement

Orders to be faxed to 1.866.211.3824.

### Standard Samples and Literature

Standard literature, product samples and color samples are available from the ROCKFON Sample and Literature department at no charge.

Phone: 1.800.323.7164/ option 2

Fax: 1.800.222.3744

Email: [cmc-customerservice@chicagometallic.com](mailto:cmc-customerservice@chicagometallic.com)

### Technical Support

Requests for technical information on ROCKFON Metal Ceilings may be placed with the Technical Services Department.

Phone: 1.800.323.7164 option 3

Fax: 1.888.329.2620

Email: [techservices@chicagometallic.com](mailto:techservices@chicagometallic.com)

### Mockups and Custom Samples

When ROCKFON has agreed to provide custom samples or mockups, the cost for them will be billed to the account. ROCKFON will issue credit for all mockups and custom sample invoices when valid orders for these products are placed with our Customer Service Department.

Phone: 1.888.991.7070

Fax: 1.866.211.3824

Email: [cmc-customerservice@chicagometallic.com](mailto:cmc-customerservice@chicagometallic.com)

### To Place Orders

Phone: 1.800.323.7164 option 1

Fax: 1.866.211.3824

# Rockfon Infinity™

## PERIMETER TRIM

### Applications

Ideal for hospitals, hospitality, retail, airports, offices, schools. Create light covers, floating islands or accents.

### Engineered, R (Reveal Edge) and Z (Razor Edge)

#### Features

- Infinity profiles are available in straight and curved heights from 2" to 12".
- Infinity R profile with continuous reveal.
- Infinity Z simulates a 0" depth ceiling.
- Attractive, smooth, rust- and distortion-free perimeter.
- Sturdy extruded aluminum.
- Integrates with standard grid and other ceiling systems.
- Metal contains no organic compounds to support mold and microbial growth.
- "QuickShip" standard sizes, or engineered to project specifications.
- Straight or curved profiles can be paired for specific applications.
- Available factory painted 180°, 360°, or with ready for field painting surface.

### D (Drywall)

#### Features

- Attractive pre-fabricated perimeters for drywall construction.
- Variety of profiles available with mitered corners.
- Infinity D available curved to 18" minimum radius.
- Trim accept 5/8" gypsum panels.
- Eliminate complex drywall framing at perimeters.
- Grooved flange accepts joint compound.
- Sturdy extruded aluminum.
- Compatible with drywall grid suspension.
- Pre-coated for improved adhesion to joint compound and paint.

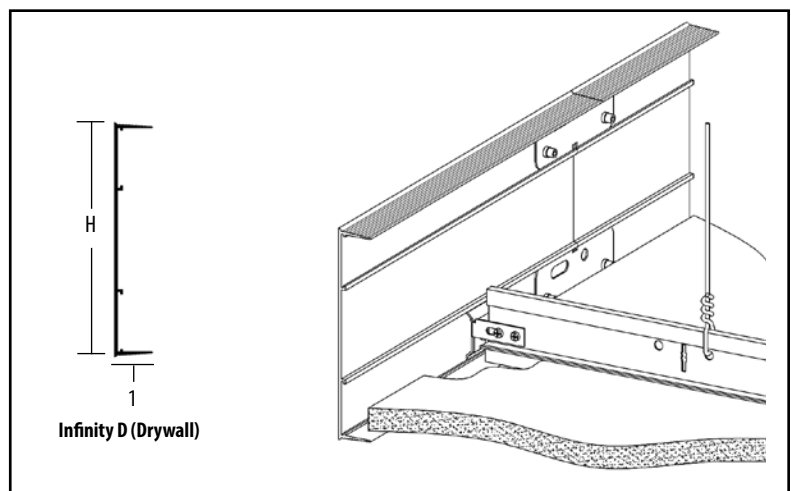
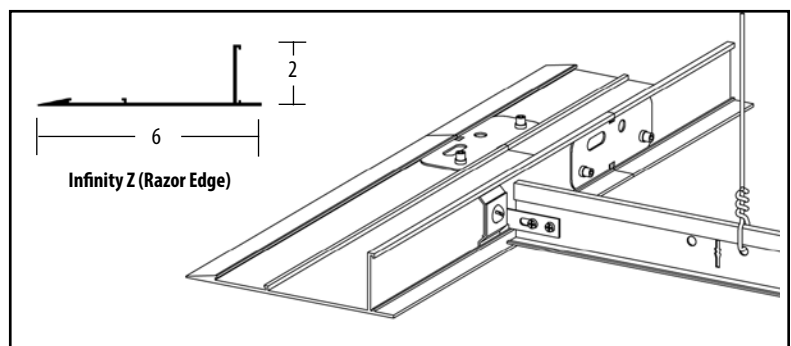
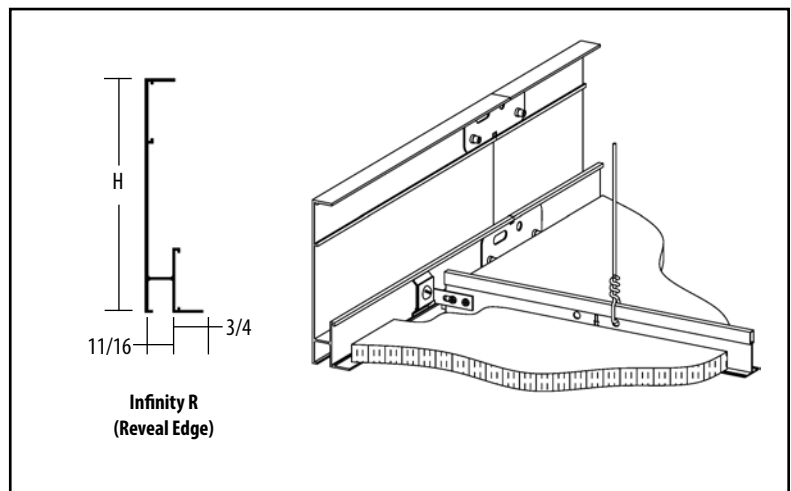
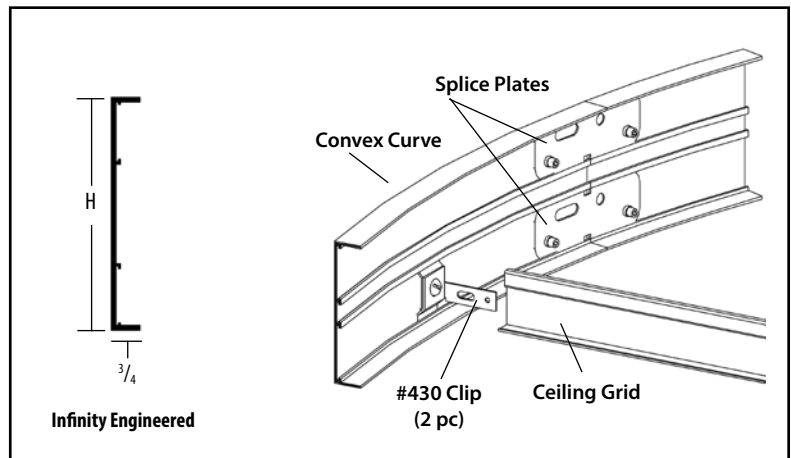

## Quick Ship Program

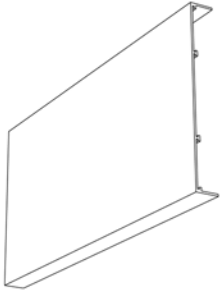

**Straight Trim**  
01470Q/01471Q/01472Q

Product Number	Dimensions			Feet	Per Order Pieces	Weight/LF
	Length	Height	Face			
<b>Trim</b> (Splices and Clips not included - sold separately)						
<b>Straight</b>						
01470Q01	12'	2"	3/4"		Per Order	0.25
01471Q01	12'	4"	3/4"		Per Order	0.55
01472Q01	12'	6"	3/4"		Per Order	0.92

Note: Pricing does not include splices and clips.

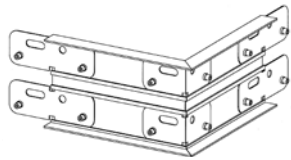

**Inside Corner 90°**  
01470IM / 01471IM / 01472IM

### Factory Mitered Corner Kits (unassembled)

2" kit contains: Two (2) 12" Straight Trim pieces with mitered corners; one (1) Corner Splice; two (2) Straight Splices.  
4", 6", and 8" kit contains: Two (2) 12" Straight Trim pieces with mitered corners; two (2) Corner Splices; four (4) Straight Splices.  
10", and 12" kit contains: Two (2) 12" Straight Trim pieces with mitered corners; three (3) Corner Splices; six (6) Straight Splices.

#### Inside Corners 90°

01470IM01	1'	2"	3/4"		Per Order	1.00
01471IM01	1'	4"	3/4"		Per Order	1.50
01472IM01	1'	6"	3/4"		Per Order	1.80

#### Outside Corners 90°

01470TM01	1'	2"	3/4"		Per Order	1.00
01471TM01	1'	4"	3/4"		Per Order	1.50
01472TM01	1'	6"	3/4"		Per Order	1.80

For 12" Corner Kits, see Accessories, pg. 6.

## Accessories

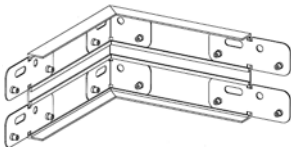

**Outside Corner 90°**  
01470TM / 01471TM / 01472TM

#### Splice Plate

414.00	Joins trim together	Per Order
--------	---------------------	-----------

#### Corner Splice Plates

417.00	Joins trim at inside corners	Per Order
429.00	Joins trim at outside corners	Per Order

#### Grid Clip

430.00	Joins grid to panel (2 parts)	Per Order
--------	-------------------------------	-----------

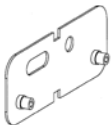

**Splice Plate**  
414

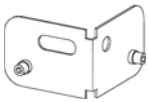

**Corner Splice Plates**  
417-429

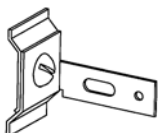

**Grid Clip**  
430

# Rockfon Infinity™ Standard (Straight Edge)

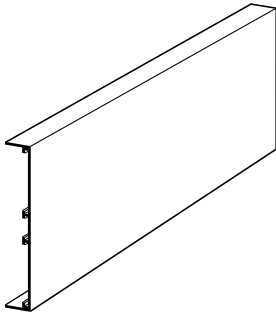

**Straight Trim**  
01470B/01471B/01472B/01473B/  
01475B/01474B

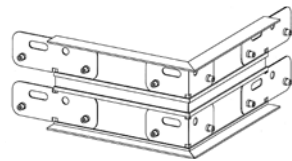

**Inside Corner 90°**  
01470IM / 01471IM / 01472IM

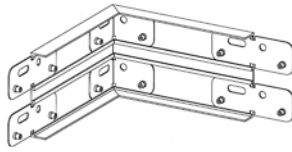

**Outside Corner 90°**  
01470TM / 01471TM / 01472TM

Product Number	Dimensions			Feet	Per Order Pieces	Weight/LF
	Length	Height	Face			

## System

### Straight – Includes Trim, Splice Plates and Grid Clips

01470Bxx	12'	2"	3/4"	Per Order	0.25
01471Bxx	12'	4"	3/4"	Per Order	0.55
01472Bxx	12'	6"	3/4"	Per Order	0.92
01473Bxx	12'	8"	3/4"	Per Order	1.10
01475Bxx	12'	10"	3/4"	Per Order	1.42
01474Bxx	12'	12"	3/4"	Per Order	1.84

### Corners – Inside

01470IMBxx	1'	2"	3/4"	Per Order	1.00
01471IMBxx	1'	4"	3/4"	Per Order	1.50
01472IMBxx	1'	6"	3/4"	Per Order	1.80
01473IMBxx	1'	8"	3/4"	Per Order	2.25
01475IMBxx	1'	10"	3/4"	Per Order	3.20
01474IMBxx	1'	12"	3/4"	Per Order	4.20

### Corners – Outside

01470TMBxx	12'	2"	3/4"	Per Order	1.00
01471TMBxx	12'	4"	3/4"	Per Order	1.50
01472TMBxx	12'	6"	3/4"	Per Order	1.80
01473TMBxx	12'	8"	3/4"	Per Order	2.25
01475TMBxx	12'	10"	3/4"	Per Order	3.20
01474TMBxx	12'	12"	3/4"	Per Order	4.20

# Rockfon Infinity™ Engineered (Straight Edge)

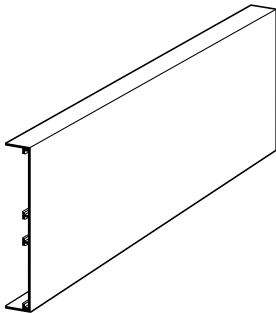

**Straight Trim**  
01470S/01471S /01472S/01473S/  
01475S/1474S

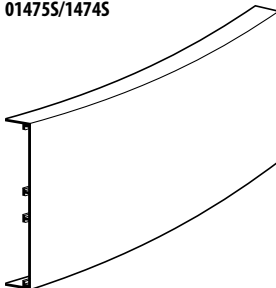

**Curved Trim**  
01470C/01471C  
/01472C/01473C/01475C/1474C

Product Number	Dimensions			Feet	Per Order Pieces	Weight/LF
	Length	Height	Face			

## System

### Straight – Includes Trim, Splice Plates and Grid Clips

01470Sxx	12'	2"	3/4"	Per Order	0.25
01471Sxx	12'	4"	3/4"	Per Order	0.55
01472Sxx	12'	6"	3/4"	Per Order	0.92
01473Sxx	12'	8"	3/4"	Per Order	1.10
01475Sxx	12'	10"	3/4"	Per Order	1.42
01474Sxx	12'	12"	3/4"	Per Order	1.84

### Curved – Includes Trim, Splice Plates and Grid Clips

01470Cxx	Varies	2"	3/4"	Per Order	0.25
01471Cxx	Varies	4"	3/4"	Per Order	0.55
01472Cxx	Varies	6"	3/4"	Per Order	0.92
01473Cxx	Varies	8"	3/4"	Per Order	1.10
01475Cxx	Varies	10"	3/4"	Per Order	1.42
01474Cxx	Varies	12"	3/4"	Per Order	1.84

## Rockfon Infinity D, R and Z

Product Number	Dimensions			Feet	Per Order	
	Length	Height	Face		Pieces	Weight/LF

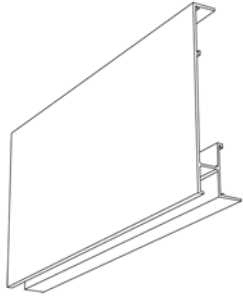

Infinity R  
04571S/04572S

### Rockfon Infinity R (Reveal Edge)

**Straight – Includes Panels, Splice Plates and Grid Clips**

04571S.xx	12'	4"	$\frac{3}{4}$ "		Per Order	0.80
-----------	-----	----	-----------------	--	-----------	------

\* Service Level applies to 01 White, 08 Black, 44 Satin Silver Metallic. Service Level is 4 for Other Colors.

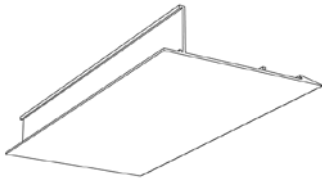

Infinity Z  
04770S

### Rockfon Infinity Z (Razor Edge)

**Straight – Includes Panels, Splice Plates and Grid Clips**

04770S.xx	12'	$1\frac{1}{2}$ "	6"		Per Order	1.00
-----------	-----	------------------	----	--	-----------	------

Note: Corners available minimum 45 degrees, maximum 135 degrees.

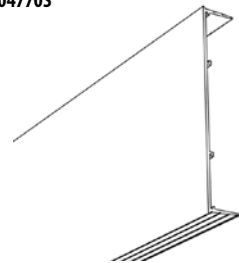

Infinity D  
04471/01473

### Rockfon Infinity D (for Drywall)

**Straight – Includes Panels, Splice Plates and Grid Clips**

04471S.00	12'	4"	$\frac{3}{4}$ "		Per Order	0.60
04473S.00	12'	8"	$\frac{3}{4}$ "		Per Order	1.20

**Curved – Includes Panels, Splice Plates and Grid Clips**

04471C.00	Varies	4"	$\frac{3}{4}$ "		Per Order	0.60
04473C.00	Varies	8"	$\frac{3}{4}$ "		Per Order	1.20

## Accessories

Product Number	Description	Per Order	
		Pieces	Weight

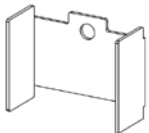

Paired Infinity Bracket  
446.36.00

### Paired Infinity Bracket

446.36.00	Joins Infinity $2\frac{1}{4}$ " apart with $\frac{3}{4}$ " opening between panels	Per Order	
446.46.00	Joins Infinity $2\frac{7}{8}$ " apart with $1\frac{3}{8}$ " opening between panels	Per Order	

Note: One clip required at top and at bottom of Infinity panel, maximum 24" on center.

### Horizontal Splice Plate

447.00	Adjustable Corner Splice Plate for Infinity Z	Per Order	
--------	---	-----------	--



Horizontal Splice Plate  
447.00

# Reflected Ceiling Plans

## Rockfon Infinity Engineered

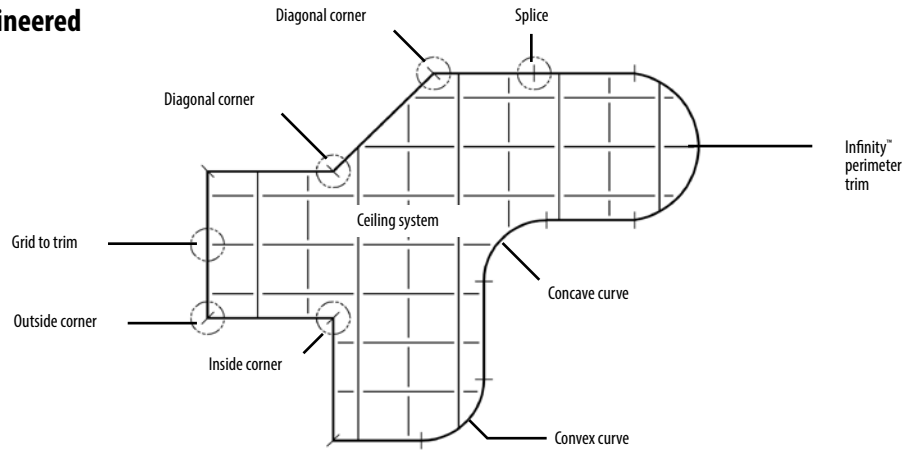

## Rockfon Infinity R (Reveal Edge)

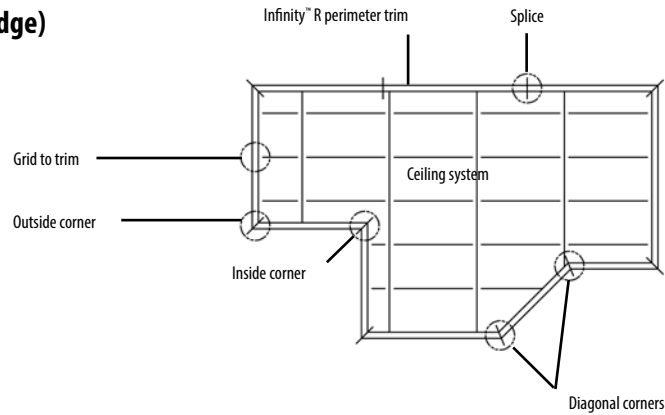

## Rockfon Infinity Z (Razor Edge)

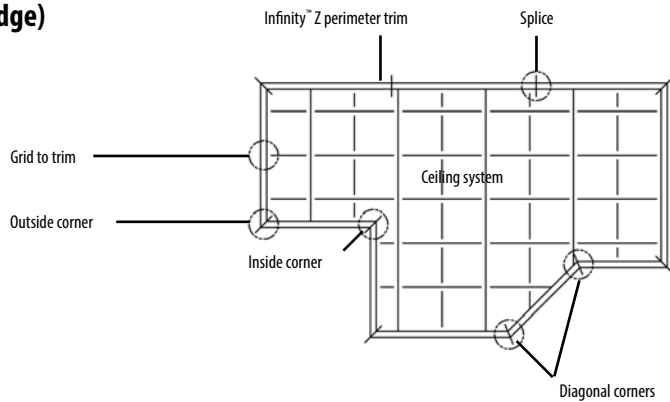

## Rockfon Infinity D (Drywall)

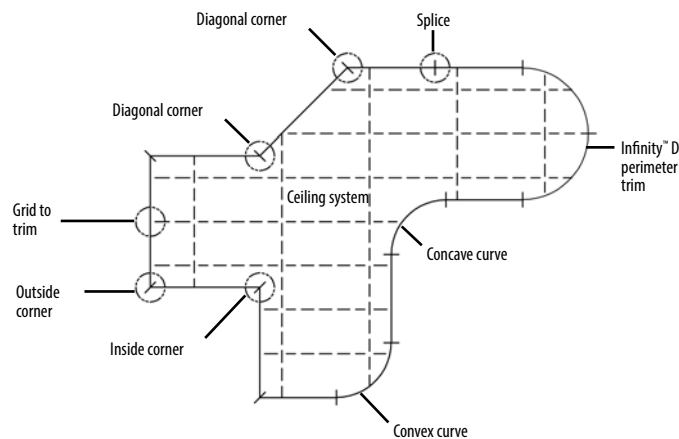

# System Integration

## Infinity Engineered

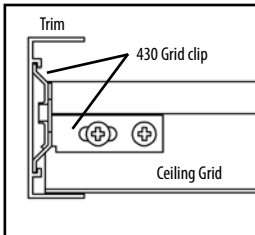

Grid to trim

## Infinity R (reveal edge)

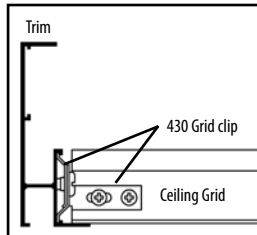

Grid to trim

## Infinity D (drywall)

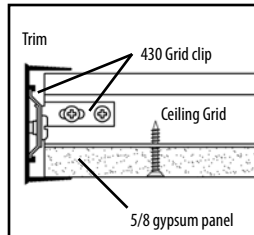

Grid to trim (panel by others)

## Infinity Paired Trim

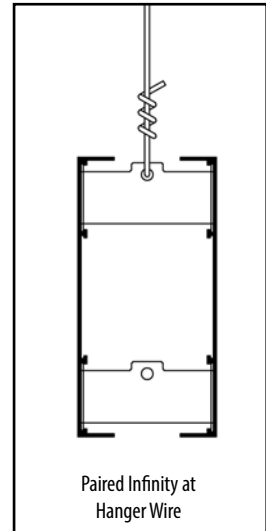

Paired Infinity at Hanger Wire

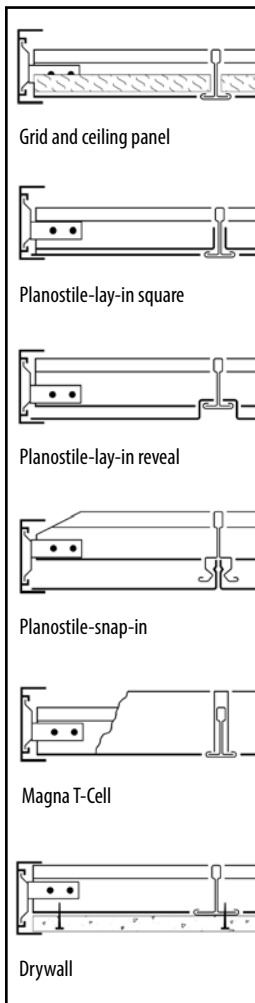

Grid and ceiling panel

Planostile™ lay-in square

Planostile™ lay-in reveal

Planostile™ snap-in

Magna T-Cell

Drywall

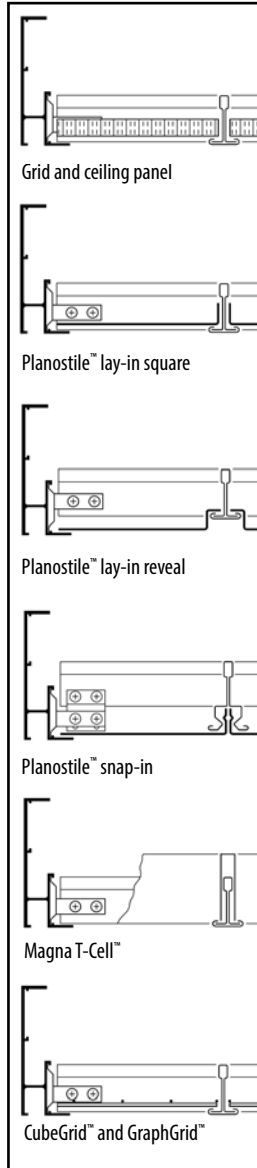

Grid and ceiling panel

Planostile™ lay-in square

Planostile™ lay-in reveal

Planostile™ snap-in

Magna T-Cell™

CubeGrid™ and GraphGrid™

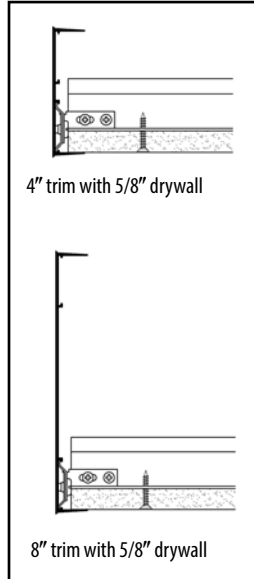

4" trim with 5/8" drywall

8" trim with 5/8" drywall

## Infinity Z (razor edge)

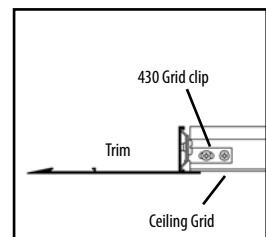

Grid to trim

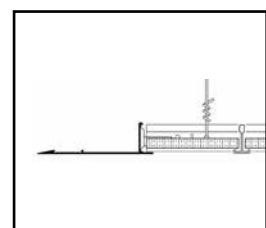

Grid and ceiling panel



# Specification Data

Product information for integration into ceiling specification

		Infinity Standard	Infinity Quick Ship	Infinity Engineered	R Reveal	Z Razor	D Drywall
<b>suspension type</b>							
<b>material</b>	extruded aluminum	•	•	•	•	•	•
<b>surface</b>	painted on exposed surfaces	•	•	•	•	•	
	painted 360° (optional)	•		•	•	•	
	primed						•
<b>size</b>	heights:	2", 4", 6", 8", 10", 12"	2", 4", 6"	2", 4", 6" 8", 10", 12"	4"	6"	4", 8"
	lengths: 12' standard and made to order	12'	12'	•	•	•	•
	straight	•	•	•	•	•	•
	curved to minimum 18" radius			•			
	paired option	•		•			
<b>fire</b>	class A: flame 0, smoke 0 per ASTM E 84	•	•	•	•	•	•
<b>performance</b>	standard to harsh interior environment	•	•	•	•	•	•
<b>suspension</b>	9/16", 15/16", 1-3/8"	•	•	•	•	•	1-3/8"
	concealed snap-bar, drywall, linear	•	•	•	•	•	•
<b>warranty</b>	1 year limited	•	•	•	•	•	•
<b>sustainability</b>	100% recycled post consumer content, 100% locally recyclable	•	•	•	•	•	•

## Colors

### Standard Painted Colors

- 01 White
- 08 Black
- 44 Satin Silver

### Premium Painted Colors

- 03 Bronze
- 21 Copper Metallic
- 23 Sandstone
- 88 Flat Black
- 113 Straw
- 167 Brick Red
- 174 Garnet
- 215 Forest Green
- 246 Federal Indigo
- 256 True Blue
- 263 Plum
- 270 Pearl Gray
- 379 Gloss White
- 386 Gloss Black
- 401 Maple\*

- 402 Oak\*
- 403 Cherry\*
- 404 Pumpkin Maple\*
- 405 Karri\*
- 425 Wet Clay
- 428 Yellow Flash
- 429 Silver Lining
- 430 Beige Breeze
- 431 Whitewash
- 432 Blonde Wood
- 437 Midnight Blue
- 438 Royal Amethyst
- 442 Burgundy Brick
- 443 Toffee Fate
- 447 Cinnamon
- 449 Fortune Gray
- 455 Cocoa Shell
- 495 Cardinal Red
- 510 Morning Dew Metallic
- 511 Autumn Metallic
- 512 Moon Glow Metallic

- 513 Sun Gold Metallic
- 515 Sterling Metallic
- 516 Flint Metallic
- 517 Emerald Metallic
- 520 Polar White
- 521 Nickel
- 524 Silver

### WoodScenes™ Painted Colors

- 800 Lazy Maple
- 801 Aged Teak
- 802 Vintage Burlwood
- 803 Burnished Cherry
- 804 Sleek Cherry
- 805 Weathered Oak

\*Coordinating Solid Paint Colors to match MetalWood® II Finishes

# Specification

## PART 1 - GENERAL

### 1.01 Scope

Provide metal suspension trim for ceiling island or fascia.

#### 1.02 Related Sections

- A. Section 09 22 26 - Suspension Systems
- B. Section 09 29 00 - Gypsum Board
- C. Section 09 54 00 - Specialty Ceilings
- D. Section 09 58 00 - Integrated Ceiling Assemblies
- E. Section 13 48 00 - Sound, Vibration, and Seismic Control
- F. Section 23 50 00 - Central Heating Equipment
- G. Section 26 50 00 - Lighting

### 1.03 References

- A. American Society for Testing and Materials (ASTM)
  1. C423 - Sound Absorption and Sound Absorption Coefficients by the Reverberation Room Method.
  2. C635 - Standard Specification for the manufacture, performance, and testing of Metal Suspension Systems for Acoustical Tile and Lay-in Panel Ceilings.
  3. C636 - Standard Practice for Installation of Metal Ceiling Suspension Systems for Acoustical Tile and Lay-in Panels.
  4. E 84 - Test Method for Surface Burning Characteristics of Building Materials.
  5. E 1264 - Classification for Acoustical Ceiling Products.
  6. E 1477 - Standard Test Method for Luminous Reflectance Factor of Acoustical Materials by Use of Integrating-Sphere Reflectometers.

### 1.04 Submittals

- A. Product data sheets listing dimensions and standard compliance.
- B. Samples: Representative sample of color and finish of all exposed materials.
- C. Shop Drawings: Reflected ceiling plans to indicate trim locations, radii, and part numbers.
- D. Approval drawings indicating ceiling layout and manufacturers details submitted and approved prior to manufacture of components.

### 1.05 Project Conditions

- A. Environmental Requirements:
  1. Verify weather tightness of area to receive suspension system prior to installation.
  2. Installation to begin only when temperature and humidity conditions closely approximate interior conditions which will exist when area is complete and occupied.
  3. Heating and air conditioning systems to be operating prior to, during, and after installation.
  4. Deliver materials in manufacturers original packaging, unopened and undamaged.
  5. Store materials in an enclosed dry location at room temperature and protect from soiling, damage, moisture and humidity.

### 1.06 Maintenance

Furnish additional material equal to \_\_\_\_\_ percent of ceiling area.

## PART 2 - PRODUCTS

### 2.01 Manufacturers

Rockfon Infinity perimeter trim by ROCKFON, 4849 South Austin Ave, Chicago IL 60638. 1-800-323-7164.

### 2.02 Materials

- A. Panels:
  1. Manufactured from extruded 6063-T5 aluminum complete with continuous integral slots for attachment of splice plates and grid clips.
- B. Profile:
  1. Rockfon Infinity profile perimeter trim for T-bar type grid acoustical ceilings (2)(4)(6)(8)(10)(12) inch high with 3/4 inch horizontal face. Panels to be (straight)(and)(curved) as indicated on approved drawings. (All corners to be factory mitered

(90 degree corner kits are allowed in place of mitered corners on straight sections). Finish to be factory applied painted finish (on outside surface)(360 degrees)(01 White)(other color \_\_\_\_\_).

2. Rockfon Infinity D profile for 5/8 inch drywall ceilings, (4)(8) inch high with 1 inch horizontal face taping flange grooved to accept joint compound. Panels to be (straight)(and)(curved) as indicated on approved drawings. Outer surface to be primed for adhesion of joint compound and field applied paint finish. Field applied paint color to be (\_\_\_\_\_).
  3. Rockfon Infinity R Reveal profile perimeter trim for T-bar type grid acoustical ceilings (4) inch high with 3/4 inch wide horizontal face and 1/2 inch wide x 3/4 inch deep continuous open reveal. Panels to be straight as indicated on approved drawings. All corners to be factory mitered. Finish to be factory applied paint (on outside surface)(360°)(01 White)(other color \_\_\_\_\_).
  4. Rockfon Infinity Z Razor profile for T-bar type grid acoustical ceilings, 6 inch wide horizontal face by 1-1/2 inch high. Panels to be straight as indicated on approved drawings. All corners to be factory mitered maximum 45 degrees. Finish to be factory applied paint on outside surface (01 White)(other color \_\_\_\_\_).
- C. Splice Plate:
    1. Manufactured from galvanized steel with set screw for splicing sections of perimeter trim.
  - D. Grid Clips:
    1. Manufactured from galvanized steel with set screw for attaching perimeter trim to suspension system members.
  - E. Paired Bracket:
    1. Manufactured from electro-galvanized steel and used for back-to-back Rockfon Infinity installations. Size bracket to maintain panel vertical surfaces (2-1/4 inch apart with 3/4 inch opening at bottom) (2-7/8 inch apart with 1-3/8 inch opening at bottom) (\_\_\_\_ inches apart).

## PART 3 - EXECUTION

### 3.01 Examination

Examine area receiving system to identify conditions which will adversely affect installation. Do not begin installation until adverse conditions have been remedied.

### 3.02 Preparation

- A. Verify actual field dimensions prior to installation.
- B. Verify adequate support for Rockfon Infinity Perimeter Trim prior to installation.
- C. Rockfon Infinity for drywall sections to be cleaned on site prior to field painting.

### 3.03 Installation

- A. Rockfon Infinity Perimeter Trim:
  1. Install after completion of above ceiling work.
  2. Install ceiling suspension system as specified and in accordance with ASTM C636.
  3. Install Infinity perimeter trim in accordance with manufacturers printed instructions and details and approved shop drawings.
  4. Rockfon Infinity perimeter trim to be supported by ceiling grid suspension system.
  5. Attach splice plates and tighten set screws to join perimeter trim.
  6. Attach trim to main tees and/or cross tees with grid clips. Field measure and cut tees to length. Attach grid clips to perimeter trim by inserting into grooves and firmly tighten set screw. Attach grid clips to main tees and cross tees with sheet metal fasteners (by contractor).
  7. Field paint Infinity for drywall sections after drywall, taping, joint compound and sanding is complete.

### 3.04 Field Quality Control

- A. Maximum deflection not to exceed 1/360 of the span.

# General Conditions of Sale

## Order Acceptance

Whenever used herein, "Seller" shall refer to ROCKFON and "Purchaser" shall refer to the party ordering or purchasing products ("Products") from Seller. Seller's price list does not constitute an offer to sell Products listed therein, but is simply provided as a convenience to prospective Purchasers. Purchaser's order to Seller shall constitute an offer to Seller to purchase Products which offer Seller may accept at its sole discretion. Acceptance shall be by a writing containing these General Conditions of Sale ("Conditions"). Acceptance of Purchaser's order or any part of it by Seller is expressly made conditional on Purchaser's assent to these Conditions. Purchaser may vary these Conditions only with the written consent of Seller. Acceptance of Products by Purchaser or failure of Purchaser to object in writing to these Conditions within ten (10) days following delivery of Products to Purchaser shall constitute Purchaser's assent to these Conditions.

## Shipment and Delivery

Seller shall deliver Product F.O.B. place of shipment. Risk of loss to Product shall pass to Purchaser upon delivery to carrier at such place of shipment. Carrier acts as Purchaser's agent. Products shall be shipped as soon as practical, or as requested by Purchaser after order acceptance by Seller. However, delivery dates shall not be of the essence, but shall be regarded as Seller's best approximation of such delivery dates. Seller may arrange freight at the request of and on behalf of Purchaser. If applicable, freight will be charged according to the Seller's freight policy in effect at time of shipment. Such policy will be provided to Purchaser via its preferred communication method and is also available in Seller's price book or upon request. All taxes, tariffs, duties or similar charges paid by Seller imposed or levied by any governmental authority in connection with the purchase, shipment, import or export of Products purchased or in connection with the procuring of materials used therein may at Seller's sole option be added to the price of Products so affected. Additional shipping charges for Products paid by Seller such as destination, storage, labor and redelivery and special or extra expenses for handling air freight, bus or other shipments may also, at Seller's sole option, be added to the price of such Products.

## Payment

Payment for all Products shall be net cash due and payable in U.S. dollars within thirty (30) days following receipt by Purchaser of shipping documents for such Products by check or bank transfer to a bank account to be designated by Seller. If accounts are paid within ten (10) days following receipt by Purchaser of the corresponding shipping documents, Purchaser shall be entitled to a one percent (1%) discount from the price of Products only. If, in Seller's sole opinion, the financial condition of the Purchaser so warrants, Seller may require advance payments or satisfactory security. In the event that the Purchaser fails to make such advance payments or furnish such security upon Seller's request, delivery of Products may be suspended without further Seller obligation. Seller may, at Seller's sole option, require payment by means of an irrevocable letter of credit opened and confirmed by a bank or banks acceptable to Seller and upon terms and conditions acceptable to Seller.

## Limited Warranty

Seller warrants to Purchaser that Products will substantially conform in quantity and quality to Purchaser's order, as accepted by Seller, provided, however, that (1) Products are inspected by Purchaser upon arrival at place of destination and any and all nonconformities are noted on the bill of lading and all other delivery documents and are attested to in writing by carrier's representative (2) Purchaser furnishes Seller with written notice of such non-conformities within fifteen (15) days following arrival of non-conforming Products at the place of destination, (3) Purchaser holds nonconforming Products for Seller's inspection (4) non-conformities occurred prior to delivery by Seller of Products F.O.B. place of shipment, and (5) Purchaser does not alter, repair, use or attempt to alter or repair any non-conforming Products. This limited warranty is Seller's only and exclusive express warranty to Purchaser. Seller disclaims any and all implied warranties including without limitation any implied warranty of merchantability or fitness for a particular purpose. Purchaser's sole and exclusive remedy against Seller shall be the replacement F.O.B. its plant or site, at Seller's option, of any Products which do not conform to Seller's limited warranty hereunder. No other remedy (including, without limitation, incidental or consequential damages for lost profits, lost sales, injury to persons or property or

any other incidental or consequential loss) shall be available to Purchaser. Purchaser agrees to include in all contracts between Purchaser and subsequent owners or users of Products, and to bring to the attention of all Purchaser's customers of Products, the following warranty disclaimer: ROCKFON disclaims any and all warranties expressed or implied, including, without limitation, any implied warranty of merchantability or fitness for a particular purpose. Purchaser shall be excluded on behalf of Seller all remedies for damage or injury to Products persons or property. In the event that Purchaser fails to comply with the foregoing obligations, Purchaser shall indemnify Seller for any liability resulting from such non-compliance and shall otherwise hold Seller harmless.

## Returns

In order to return any Products to Seller, Purchaser must first obtain prior authorization for products eligible for return, and receive a Return Goods Authorization number from Seller's home office. All authorized returns are subject to a 20% restocking charge. Seller will only issue credit for Service Level "0" material received at the designated company facility with the Return Goods Authorization appearing on the material, and after being inspected and determined by Seller to be in resalable condition. Purchaser is solely responsible for arranging and prepaying for all return freight. Seller will not be responsible for any damage in transit on material returned at customer's request, and will not file freight claims on such damaged material. When these terms are met, seller will issue appropriate material credit less the restocking charge.

## Default, Termination and Suspension of Delivery

Seller reserves the right, among other remedies, either to cancel Purchaser's order or suspend further deliveries of Products thereunder in the event that (1) Purchaser fails to pay for any one shipment of Products when payment for such shipment becomes due; (2) Purchaser fails to make any advance payments or satisfactory security demanded by Seller pursuant to paragraph two of PAYMENTS section above; or (3) Purchaser fails or refuses to accept any delivery of Products ordered from Seller. Delivery of Products may be suspended in whole or in part in case of any event beyond Seller's control, including, but not limited to, explosion, fire, shortage of fuel, power or raw materials flood strike lockout, injunction, riot, insurrection, war, national emergency, government act, or act of God.

## Miscellaneous

No failure or delay on the part of Seller in exercising any right, power or privilege hereunder shall operate as a waiver thereof or of any other right, power or privilege hereunder nor shall any single or partial exercise of any such right power or privilege preclude any other right, power or privilege. The rights or remedies of Seller hereunder are cumulative and not exclusive of any rights or remedies which it may otherwise have. The parties hereto may correct stenographic and clerical errors without liability. Purchaser may not assign the order without the express written consent of Seller. All notices to be given hereunder by either party to the other party shall be dispatched by certified or registered mail return receipt requested addressed to the last known post office address of such other party. Any such notice shall be deemed received within five (5) days following any such dispatch if mailed from within the United States of America and ten (10) days if mailed from outside the United States of America. Either party may change its address by notice to the other party. These Conditions shall be governed by and interpreted in accordance with the laws of the State of Illinois, United States of America, and all disputes hereunder that cannot be amicably resolved by the parties thereto must be settled in a court of competent jurisdiction within the State of Illinois, United States of America. The provisions of these Conditions shall be severable one from the other so that should any provision be held legally unenforceable by a court of competent jurisdiction, the remaining provisions shall remain in effect.

ROCKFON Ceiling Products



Metal

Perimeter Trim/ Curvilinear / Flat Metal Panel / Embossed Metal Panel / Linear / Open Plenum / Security



Grid

General Applications / Special Applications / Drywall Applications



ROCKFON, LLC 4849 SOUTH AUSTIN AVE., CHICAGO, IL 60638 / USA and Canada: 800-323-7164 / Fax: 800-222-3744 / rockfon.com

Date: 06.2014 | Subject to alterations in range and product technology without prior notice. ROCKFON accepts no responsibility for printing errors.

SNL0142E2014